



ECO HOT™

Installation Manual and Owners Guide

Model no. WHO_321064-NG, WHO_321064-LP Instantaneous Water Heater

For Exterior Use Only

**ATTENTION: Prior To Installation, You Must Check Sizing Of Gas Pipe Line
For Proper BTU's. See page 8 For Sizing Chart.
(Be Sure To Calculate Total BTU's of all Appliances On Gas Line)**

Please read this manual carefully

Domestic Hot Water Use in Commercial Applications Will Limit Warranty



WARNING: IF THE INFORMATION IN THESE INSTRUCTIONS IS NOT FOLLOWED EXACTLY, A FIRE OR EXPLOSION MAY RESULT, CAUSING PROPERTY DAMAGE, PERSONAL INJURY OR DEATH.

- Do not store or use gasoline or other flammable vapors and liquids in the vicinity of this or any other appliance.
- **WHAT TO DO IF YOU SMELL GAS**
 - Do not try to light any appliance.
 - Do not touch any electrical switch; do not use any phone in your building.
 - Immediately call your gas supplier from a neighbor's phone. Follow the gas supplier's instructions.
 - If you cannot reach your gas supplier, call the fire department.
- **Installation and service must be performed by a qualified installer, service agency or the gas supplier.**

******* IMPORTANT*******

Upon completion of the installation, these instructions should be handed to the user of the appliance for future reference.

This product is not approved for manufactured homes (mobile home), recreational vehicles (RV) or boats.

TABLE OF CONTENTS

FEATURES:	3
SPECIFICATIONS:	3
INSTALLATION INSTRUCTIONS:	3
Finding the Proper Location	
Mounting	
Installation of Gas Line	
Installation of Cold Water Supply	
Installation of Hot Water Outlet	
Installation of Power Supply	
GENERAL RULES TO FOLLOW FOR SAFE OPERATION	5
Anti Freeze Device	6
Gas Supply	6
Gas Piping, Connections and Gas Regulator	
Gas Line Sizing (Natural Gas and LP Gas)	
High Altitude Operation	
Water Connections	9
TURNING THE WATER HEATER ON	
TURNING THE WATER HEATER OFF	
Connecting the pressure relief valve (PRV)	
OPERATING INSTRUCTIONS	11
WHAT TO DO IF YOU SMELL GAS	
MAINTENANCE AND SERVICE	12
TROUBLE SHOOTING	16
Introduction	
No spark at the pilot	
Flow	
Error Code	
PARTS LIST	20
Figure 1: Interior Diagram	22
Figure 2: Plumbing Installation	23
Figure 3: Front & Side Views	23
Figure 4: Direct Vent Terminal	24
Figure 5: Wiring Diagram	26
Figure 6: Tankless Water Heater with Domestic Recirculation Loop	27

Note:

Specifications are subject to change without prior notice.

FEATURES:

- Freeze protection device 5°F(-15°C);
- Constant temperature control;
- Copper heating coils for endless supply of hot water;
- Self diagnostic function with malfunction number display on remote control.
- Automatic overheating protection shut-off sensor;
- Stainless steel burners with stabilized blue flame;
- Compact space saver: mounts on a wall with 4 screws;
- Easily removable one-piece cover;
- Easy one person installation;
- Red LED indicator display °F & °C water temperatures on remote controller;

ECOHOT™ WHO-321064-LP, WHO-321064-NG

SPECIFICATIONS:

- Gas input max: 218,000 Btu/hr
- Min: 18,000 Btu/hr
- Water Connection 3/4" Thread fitting NPT
- Box Size: H x W x D=31" x 18" x 11"
- Actual Size: H x W x D=24" x 15" x 8"
- Gas Connection 3/4" NPT thread
- Net Weight 44 lbs, Shipping Weight 50 lbs.
- 5.8 GPM (21 L) at 65° rise
- 8.4 GPM (31 L) at 45° rise
- Maximum Working Water Presser 150PSI (1.035 MPa)
- .8 GPM Flow Rate to Activate ECOHOT™ Water Heater.

Temp Rise Above Ground Water	30 °F	40 °F	50 °F	60 °F	70 °F	80 °F
Flow Rate (Gal/Min.)	12.5	9.4	7.5	6.3	5.4	4.7
Temp Rise Above Ground Water	90 °F	100 °F	110 °F	120 °F	130 °F	
Flow Rate (Gal/Min.)	4.2	3.8	3.4	3.1	2.9	



Note: Specifications are subject to change without prior notice. Local and State codes must be adhered to prior to installation.

INSTALLATION INSTRUCTIONS:

MUST READ PRIOR TO INSTALLATION

Always wear safety glasses and gloves

Must be mounted a min. of 12" above the floor

Finding the Proper Location:

1. Make sure you install your tank-less water heater in an area that exhaust has 4ft or more from any window or door (check local codes). Exhaust vent must be a min. of 7ft. above public walk ways or paved drive ways. Minimum 3 feet below eaves or gutters. **See Fig 4.**
2. **Do not install in home or enclosed area.**



DANGER

Vapors from flammable liquids will explode and catch fire causing death or severe burns.

Do not use or store flammable products such as gasoline, solvents or adhesives near the water heater.

Mounting:

1. Use stud finder or other common method to find wall studs or wood under stucco. Mount water heater with a minimum of 2 1/2" non-corrosive wood screws. **See Fig 3**
2. Use four (4) 1" wood screws for wood siding or molly type screws to mount water heater to stucco or concrete. **(Note Use corrosion resistant screws)**

Installation of Gas Line:

1. Ensure that your gas supply is properly sized, check with your local gas company and gas chart in this manual.
2. Install a gas shut off valve on the gas supply line. (See Fig. 2)
3. Be sure to install a sediment trap and a union connection. (See Fig. 2).
4. Make sure to check the name plate for the correct gas type supply NG or LP.

Installation of Cold Water Supply:

The inlet line, cold water supply is on the right hand side (always use a min. of 3/4" copper pipe, or 3/4" flex line). Install shut off valve on water supply line. (See Figure 2)

Installation of Hot Water Outlet:

1. The outlet line, hot water supply is on the left hand side (always use a min. of 3/4" copper pipe or 3/4" flex line). Install shut off valve on water supply line. (See fig. 2)
2. Your hot water lines should be kept short to save water and energy, thus placement of this appliance is important to save hot water costs. **NOTE:** Hot water lines should be insulated. (Follow local codes).
3. When facing the heater the hot water outlet is on your left. Keep water inlet and outlet pipes to no less than 3/4" diameter to allow full flow capacity.

Remember:

1. Water pressure must be sufficient to activate the heater when drawing hot water from the top floor.
2. If the hot and cold connections to the heater are reversed, the heater will not function.
3. 3/4" Copper or brass fittings work best when connected to the connectors. (See Fig. 2)
4. The flexible type connectors (3/4" ID min.) will make installation easier and seals to the water valve by means of a union connection with a washer type gasket at the joint. No pipe sealant or Teflon tape is to be used at this joint.
5. Be certain there are no loose particles or dirt in the piping. Blow out or flush the lines before connecting to the **ECOHOT™**. Full port valves should be installed on both the cold water feed line and the hot water outlet line to facilitate servicing the heater.
6. For installation on a private well system, be sure that the **water pressure** is set between 30 and 50 PSI. (See Fig. 2)

Installation of Power Supply

The **ECOHOT™** water heater requires an electrical power supply from 120 VAC 60HZ circuit and needs to be properly grounded.

TURNING THE WATER HEATER ON:

1. Open cold water supply valve, open hot water supply valve, and open hot water faucet outlet to remove any air in the water lines.
2. Turn on gas valve.
3. Plug-in power supply.
4. Press the on/off button on remote to ON then set temperature (**ECOHOT™** Recommends 120°F/49°C or less) and open water outlet in home. If a remote controller is provided, adjust the temperature below 120°F/49°C (Default temperature), there is a hot water scald potential if the remote controller is set too high. Should overheating occur or the gas supply fail to shut off, turn off the manual gas control valve to the appliance. If water heater does not get hot close and open outlet again to remove air from gas line, if this does not work refer to trouble shooting.

TURNING THE WATER HEATER OFF:

1. Shut off hot water faucet.
2. Shut off gas valve.

Please Note:

CSC recommends that installers use large washers with the screws used to hang the heater. (See **Figure3**)

Before installing the appliance, be certain you have the correct heater for your type of Gas-Propane or Natural Gas. Identification labels are found on the shipping box, and on the rating plate, which is located on the right side panel of the cover.



WARNING: California Proposition 65 lists chemical substances known to the state to cause cancer, birth defects, death, serious illness or other reproductive harm. This product may contain such substances, be their origin from fuel combustion (gas, oil) or components of the product itself.

GENERAL RULES TO FOLLOW FOR SAFE OPERATION

1. You should follow these instructions when you install your heater. In the Appliance states: The installation must conform with local codes or, in the absence of local codes, the National Fuel Gas Code ANSI Z223.1/NFPA54.

In Canada: The installation should conform to CSA B149. Natural Gas and Propane Installation Code and /or local installation codes.

2. Placement of water heater is important. (Check your local building codes before installation). If not installed correctly, fatal accidents can be caused.

3. The appliance must be electrically grounded in accordance with local codes or, in the absence of local codes, with the National Electrical Code, ANSI/NFPA 70 and/or the CSA C22.1, Canadian Electrical Code.

4. The appliance and its individual shutoff valve must be disconnected from the gas supply piping system during any pressure testing at pressures in excess of 1/2 PSI (3.5Kpa)

5. The appliance must be isolated from the gas supply piping system by closing its individual manual shut off valve during any pressure testing of the gas supply piping system at test pressures equal to or less than 1/2 PSI (3.5Kpa).

6. The appliance and its gas connection must be leak tested with soapy water solution before placing the appliance in operation.

7. Keep water heater area clear and free from combustibles and flammable liquids. Do not locate the heater over or under any material, which might burn. (See clearances page 19)

8. Should over heating occur or the gas supply fails to shut off, turn off the manual gas control valve to the appliance.

9. Do not use this appliance if any part has been underwater. Immediately call a qualified service technician to inspect the appliance and to replace any part of the control system and any gas control, which has been underwater.



WARNING:

The heater may still operate even when improperly installed. It will, however, be less efficient and could eventually damage the heater. It could even result in human sickness or death due to carbon monoxide poisoning. Place your heater as far away from a door or window as possible (4 ft min).

Anti Freeze Device

This heater is designed for and approved for outside installation.

This water heater has a built in anti freezing device and it has be rated for temperatures down to 5 °F (-15 °C) in a wind free environment. Operating this appliance in temperatures lower than 5 °F will void the warranty. If temperatures drop below 5 °F it may cause this appliances heat exchange to be damaged. To avoid freezing, drain water from water heater.

This appliance needs to be plugged in electrical power at all times for anti freezing device to be operational.



CAUTION: Only the pipes within the water heater are protected by the anti-freeze devices on the **ECOHOT™**. Any hot or cold water pipes located outside of the appliance will not be protected. Properly protect and insulate these pipes from freezing.

Gas Supply

- It is recommended that the Natural Gas &LP Pipe be standard weight or steel (galvanized or black) or yellow brass (containing not more than seventy five (75) percent copper) Approved PE pipe may be used in exterior buried piping systems. All such pipe shall be either new or previously used for no other purpose than conveying gas; and must be in good condition and free from internal obstructions. Burred ends shall be reamed to the full bore of the pipe. All fittings used shall be of malleable iron, yellow brass or approved plastic fittings. (See gas chart)

THESE FIGURES ARE FOR ECOHOT™ SUPPLY ONLY; ALL OTHER APPLIANCES IN THE BUILDING WILL NEED TO BE INCLUDED IN THE PIPE SIZING.

National Fuel Gas Code requires that a sediment trap (trip leg) be installed on gas appliances not so equipped. The drip leg must be accessible and not subject to freezing conditions. Install in accordance with the recommendation of the local gas supplier.



WARNING: The heater must be disconnected from the gas supply piping system at test pressures testing of that system during any pressure testing of that system at test pressure in excess of 0.5 PSI The water heater must be isolated from the gas supply piping system by closing the manual shutoff valve during any pressure testing of the gas supply piping system at test pressures equal to or more than 0.5 PSI.

This water heater includes a pressure regulator and must not be operated at gas supply pressures in excess of 0.5 PSI. If overpressure has occurred, such as through improper testing of the gas lines or malfunction of the supply system, the gas valve and regulator must be checked for safe operation. Make sure that the regulator vent is protected against blockage.

For Natural Gas, the minimum inlet gas pressure is 6 inches W.C.(1.5kPa). For LPG, the minimum inlet gas pressure is 10 inches W.C.(2.5kPa)

When your connections are made, check for gas leaks at all joints (this includes all existing piping). Apply some soapy water to all gas fittings and gas valve. **Soap bubbles are a sign of a leak.**

Note: No substance other than air, carbon dioxide or nitrogen can be introduced into the gas piping.

NOTE: If you have a leak, shut off the gas. After verifying the leak, tighten appropriate fittings to stop leak. Turn the gas on and check again with a soapy solution. **Never test for gas leaks using a match or flame.**

Gas Piping, Connections and Gas Regulator

Before connecting the gas supply, check the rating plate on the right side of the right front cover to be sure that the heater is rated for the same gas to which it will be connected.

In the Appliance States: The installation must conform with local codes or, in the absence of local codes, the National Fuel Gas Code ANSIZ223.1/NFPA54.

In Canada: The installation should confirm with CGAB149 INSTALLATION CODES and/or local installation codes.

Gas Line Sizing:

The gas supply piping should be sized according to the Applicable Plumbing Code for a maximum draw of 218,000 BTU. First determine the effective length of the gas supply line by measuring the actual length of piping, and then adding 5 ft. for every elbow or "T" to the actual length. Use the charts below to determine the pipe diameter necessary to accommodate the BTU demand of the appliance. If there is more gas drawing appliances on the line, size according to the maximum amount of BTU demand.

Maximum **Natural Gas** Delivery Capacity in Cube Feet per Hour(0.60 Specific Gravity, 0.5"WC Pressure Drop)

Pipe Size	Length in Feet										
	10'	20'	30'	40'	50'	60'	70'	80'	90'	100'	125'
1/2"	174	119	96	82	73	66	61	56	53	50	44
3/4"	363	249	200	171	152	138	127	18	111	104	93
1"	684	470	377	323	286	259	239	222	208	197	174
1 1/4"	1404	965	775	663	588	532	490	456	428	404	358
1 1/2"	2103	1445	1161	993	880	798	734	683	641	605	536
2"	4050	2784	2235	1913	1696	1536	1413	1315	1234	1165	1033
2 1/2"	6455	4437	3563	3049	2703	2449	2253	2096	1966	1857	1646
3"	11412	7843	6299	5391	4778	4329	3983	3705	3476	3284	2910

*Contact the Gas Supplier for Btu/Cubic Ft. of the Supplied Gas.

The formula for figuring the cubic feet per hour required is:

$$CFH = \frac{\text{Gas Input of Water Heater(BTU/HR)}}{\text{Heating Value of Gas(BTU/Cubic FT)}}$$

Maximum **Liquefied Petroleum(Undiluted)** delivery Capacity in Thousand of Btuh(0.5" WC Pressure Drop)

Pipe Size	Length in Feet												
	10'	20'	30'	40'	50'	60'	70'	80'	90'	100'	125'	150'	200'
1/2"	275	189	152	129	114	103	96	89	83	78	69	63	55
3/4"	576	693	315	267	237	217	196	185	173	162	146	132	112
1"	1107	732	590	504	448	409	378	346	322	307	275	252	213
1 1/4"	1220	1149	1121	1103	913	834	771	724	677	630	567	511	440
1 1/2"	1330	1229	1185	1155	1141	1127	1118	1108	1102	976	866	787	675
2"	1622	1433	1346	1299	1264	1239	1220	1204	1192	1811	1606	1496	1260

**For reference only. Please consult gas pipe manufacture for actual capacities.

This chart is only for Black Iron piping and is only for ECOHOT Water Heater at high fire condition.

High Altitude Operation

For high altitude installations in Canada above 2,000 Ft to 4,500 Ft, this water heater's Gas Supply

needs to be derated 5% for Inside Models and 10% for Outside Models (See owner's manual for instructions on de-rating)

For high altitude installations in US above 7,500 Ft, contact Greenworks Unlimited for instructions.

Do not alter the orifice jets or gas supply pressure.

This Water Heater is not approved above 9,000 ft (2,743m).

De-rating Manifold Pressure

De-rating Manifold Pressure Table

	WH-201061, WHO-201059		WH-321063, WHO-321064	
	LPG	NG	LPG	NG
Normal Max. Manifold Pressure	7.0 inches W.C. (1750 ± 30)Pa	3.1 inches W.C. (780 ± 30)Pa	8.0 inches W.C. (2000 ± 30)Pa	4.4 inches W.C. (1100 ± 30)Pa
Normal Min. Manifold Pressure	1.4 inches W.C. (350 ± 20)Pa	0.6 inches W.C. (150 ± 20)Pa	1.4 inches W.C. (350 ± 20)Pa	0.6 inches W.C. (150 ± 20)Pa
De-rating 5% Max. Manifold Pressure*	6.3 inches W.C. (1580 ± 30)Pa	2.8 inches W.C. (705 ± 30)Pa	7.2 inches W.C. (1800 ± 30)Pa	4.0 inches W.C. (990 ± 30)Pa
De-rating 5% Min. Manifold Pressure*	1.3 inches W.C. (315 ± 20)Pa	0.5 inches W.C. (135 ± 20)Pa	1.3 inches W.C. (315 ± 20)Pa	0.5 inches W.C. (135 ± 20)Pa
De-rating 10% Max. Manifold Pressure*	5.7 inches W.C. (1420 ± 30)Pa	2.5 inches W.C. (635 ± 30)Pa	6.6 inches W.C. (1650 ± 30)Pa	3.6 inches W.C. (895 ± 30)Pa
De-rating 10% Min. Manifold Pressure*	1.1 inches W.C. (285 ± 20)Pa	0.5 inches W.C. (125 ± 20)Pa	1.1 inches W.C. (285 ± 20)Pa	0.5 inches W.C. (125 ± 20)Pa

(1 inch water column equals 249.089 Pascals (at 4 degree Celsius), 1 Pa=0.004015 in.W.C.)

*: For High Altitude installation in Canada between 2,000 Ft and 4,500 Ft , Indoor Model de-rating 5% and outdoor model de-rating 10%,

** : Natural Gas Pressure Inlet: Max. 10.5” WC(2.6kPa), Min. 6” WC(1.5kPa).

***: LP Gas Pressure Inlet: Max. 14” WC(3.5kPa). Min. 10” WC(2.5kPa).

1. Connecting manometer

- ◆ Shut off gas.
- ◆ Remove front cover and locate Manifold Pressure measuring point, see Fig:Test Point below “T”.

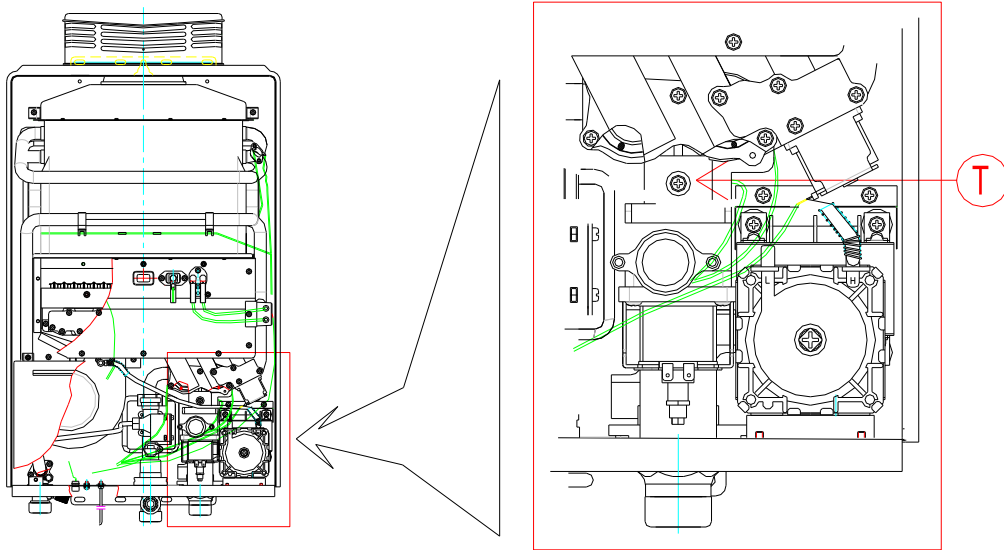

Fig: Test Point

- ◆ Loosen screw from test point and connect manometer tube on test point.

2. Maximum Manifold Pressure adjustment

- ◆ Plug in Power cord.
- ◆ Turn on all hot water taps served by the water heater.
- ◆ Adjust the temperature setting up to 140 F (60 C), make sure water heater's all burners working.

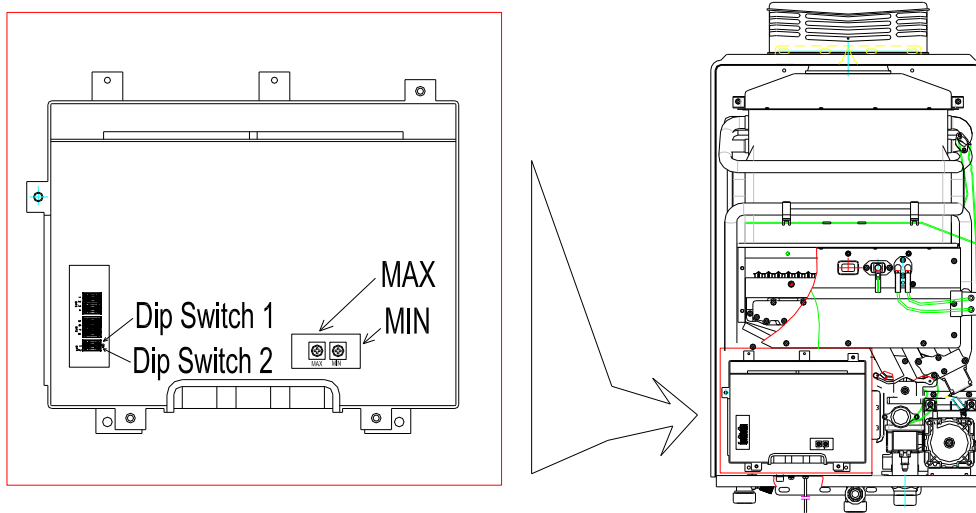

Fig: Switches

- ◆ Adjust Dip Switch 1 and Switch 2 to ON position, let water heater work on full capacity conditions, on the condition of Inlet Gas Pressure is 11 inches W.C. (2740Pa) for LPG and 7 inches W.C. (1740Pa) for Nature Gas. Refer Fig:Switches.
- ◆ Use a small crossing screw driver adjust The Adjustable Resistance of PCB which marked "MAX", to meet the data of De-rating Manifold Max. Pressure from the De-rating Manifold Pressure Table.

3. Minimum Manifold Pressure adjustment

- ◆ Adjust Dip Switch 1 to OFF position,
- ◆ Use a small crossing screw driver adjust The Adjustable Resistance of PCB which marked “MIN”, to meet the data of De-rating Manifold Min. Pressure from the De-rating Manifold Pressure Table.
- ◆ Then adjust Switch 2 to OFF position.

4. Check Manifold Pressure

- ◆ Shut off all water taps, and unplug water heater's power cord.
- ◆ Plug the power cord and turn on all water taps, check the Maximum and Minimum Manifold Pressure again as Step 2 and Step 3.
- ◆ Seal back Manifold Pressure measuring point.

Water Connections

When facing the heater, the cold water inlet is on your right and the hot water outlet is on your left. Although water piping throughout your structure may be other than copper, we recommend that copper piping be used for at least three feet before and after the heater (follow local codes). Keep water inlet pipe to no less than 3/4" diameter to allow the full flow capacity.

Remember that water pressure must be sufficient to activate the heater when drawing hot water from the top floor. If the hot and cold connections to the heater are reversed, the heater will not function. 3/4" Copper or brass fittings work best when connected to the connectors. (See Fig. 2) The flexible type connectors will make installation easier and seals to the water valve by means of a union connection with a washer type gasket at the joint. No pipe dope or thread tape is to be used at this joint. Be certain there are no loose particles or dirt in the piping. Blow out or flush the lines before connecting to the **ECOHOT™**. Full port valves should be installed on both the cold water feed line and the hot water outlet line to facilitate servicing the heater. For installation on a private well system, be sure that the **water pressure** is set between 30 and 50 PSI. (See Fig. 2) Plumbing connections for the **ECOHOT™**

Connecting the pressure relief valve (PRV) (PRV Must be Brass, 3/4" and, rated at 150 PSI), Install PRV discharge line 6" above floor drain or to exterior of home (check local building codes). (See Figure 2) A listed pressure relief valve must be installed at the time of installation and needs to be 3/4" and 150PSI. No valve is to be placed between the PRV and the heater. No reducing coupling or other restriction may be installed in the discharge line.

The discharge line must be installed such that it allows complete drainage of both the pressure relief valve (PRV) and the line to a suitable place for disposal.

The location of the PRV must be readily accessible for servicing or replacement, and be mounted as close to the water heater as possible. See Fig. 2. To install the PRV, a suitable fitting connected to an extension on a "T" fitting can be sweated to the hot water line. (See Fig. 2)

(PRV is included with this water heater for Canada only).

OPERATING INSTRUCTIONS

Before proceeding with the operation of the heater make sure that the system is filled with water.

Open the cold water inlet supply to the heater fully. Open a hot water faucet to permit the water to fill the heater and the piping and to eliminate the air trapped in the system. Close the hot water faucet after the water flows freely and all the air has escaped from the system. The water heater is now ready to operate.

FOR YOUR SAFETY READ BEFORE OPERATING YOUR HOT WATER HEATER



WARNING: If you do not follow these instructions exactly, a fire or explosion may result causing property damage, personal injury or loss of life.

WHAT TO DO IF YOU SMELL GAS

- Do not try to light any appliance.
- Do not touch any electric switch.
- Do not use any phone in your building
- Immediately call your gas supplier from a neighbor's phone or cell phone from outside the building and follow the gas supplier's instructions.
- If you cannot reach your gas supplier, call the fire department.

MAINTENANCE AND SERVICE



WARNING: Unplug the electrical power supply and close the manual gas control valve and the manual water control valve and turn off remote before servicing.

Immediately after installation:

1. Check for gas leaks with soapy water solution.
2. Check that the water heater is mounted securely.
3. Check the gas pressure.
4. Keep the area around the water heater clear. from combustible materials, gasoline and other flammable vapors and liquids. Check every month for overgrown vegetation.
5. The appliance should be checked once a year or as necessary by a licensed technician. If repairs are needed, any repairs should be done by a licensed technician.



CAUTION: Label all wires prior to disconnection when servicing controls. Wiring error can cause improper and dangerous operation. Verify proper operation after servicing.

The following systems and parts should be checked at least once a year:

1. Venting system
2. Burner
3. Manual operation of the pressure relief valve to ensure correct operation. When operating the pressure relief valve, avoid contact with hot water coming out and avoid water damage.
4. Cleaning
5. Heat exchanger requires flushing with a descaling solution. Scale build up will void your warranty and shorten the life of your water heater. To remove the front cover, first remove the four screws, and then pull main cover out toward you and lift up and out.

THE FOLLOWING OPERATIONS SHOULD ONLY BE PERFORMED BY A LICENSED TECHNICIAN.

Venting System: Should be checked annually. Clean as needed. Before removing cover appliance should be unplugged, Water and gas valve should be shut off.

Main Burner Flames: The main burner flames should be blue. Yellow flames could be a sign of wrong size gas orifices or dirty burners, or a blockage on the heat exchanger fins. If some burners have yellow flames while others have blue flames, it is likely that dust, lint or spider webs have partially clogged the burner venturi. To clean the burners, contact a gas service person.

Main Burner Flame Visual Check

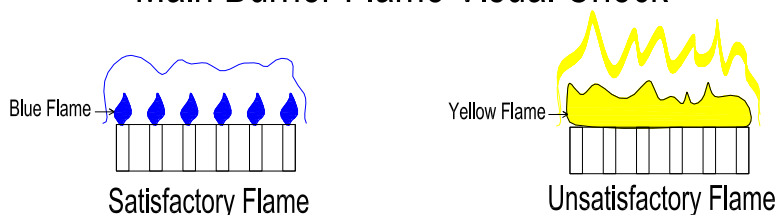

Cleaning: The water heater should be cleaned annually, keep the dust away from flue gas passageway. See the Cleaning Instructions below.

Cleaning Instructions

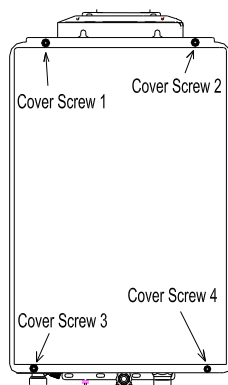

Water heater with Cover

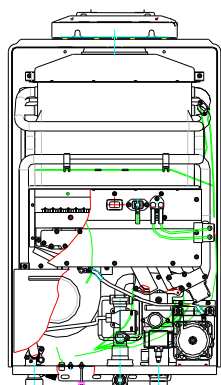

Water heater without Cover

- 1) Turn off power, shutoff gas supply
- 2) Wait one hour to cool down water heater
- 3) Remove the front cover, by taking out Cover Screw 1 to 4
- 4) Using compressed air or equivalent to clean the area between the fins and the heat exchanger.
- 5) Do not unscrew or move any other parts of water heater.
- 6) After Cleaning, put the front cover back.



DANGER: Hot water heater temperature over 125 °F can cause severe burns instantly or death from scalding. Children, the disabled and the elderly are at the highest risk of being scalded. Feel water temperature before bathing or showering.



WARNING: Read and follow water heater warnings and instructions. If owner's manual is missing or damaged contact the retailer or go to "Greenworksunlimited.com" for a copy.

Mineral Scale Build-up: The ECOHOT™ Water heater should be set at lower temperature (ECO HOT™ Recommends 120°F/49°C or less) to help avoid accumulating mineral built-up. If however the water has a high mineral content, periodic descaling may be necessary. The heating coils should be flushed with a descaling solution. The descaling is done only to the heat exchange or the chemicals will damage other parts.

Flush Procedure

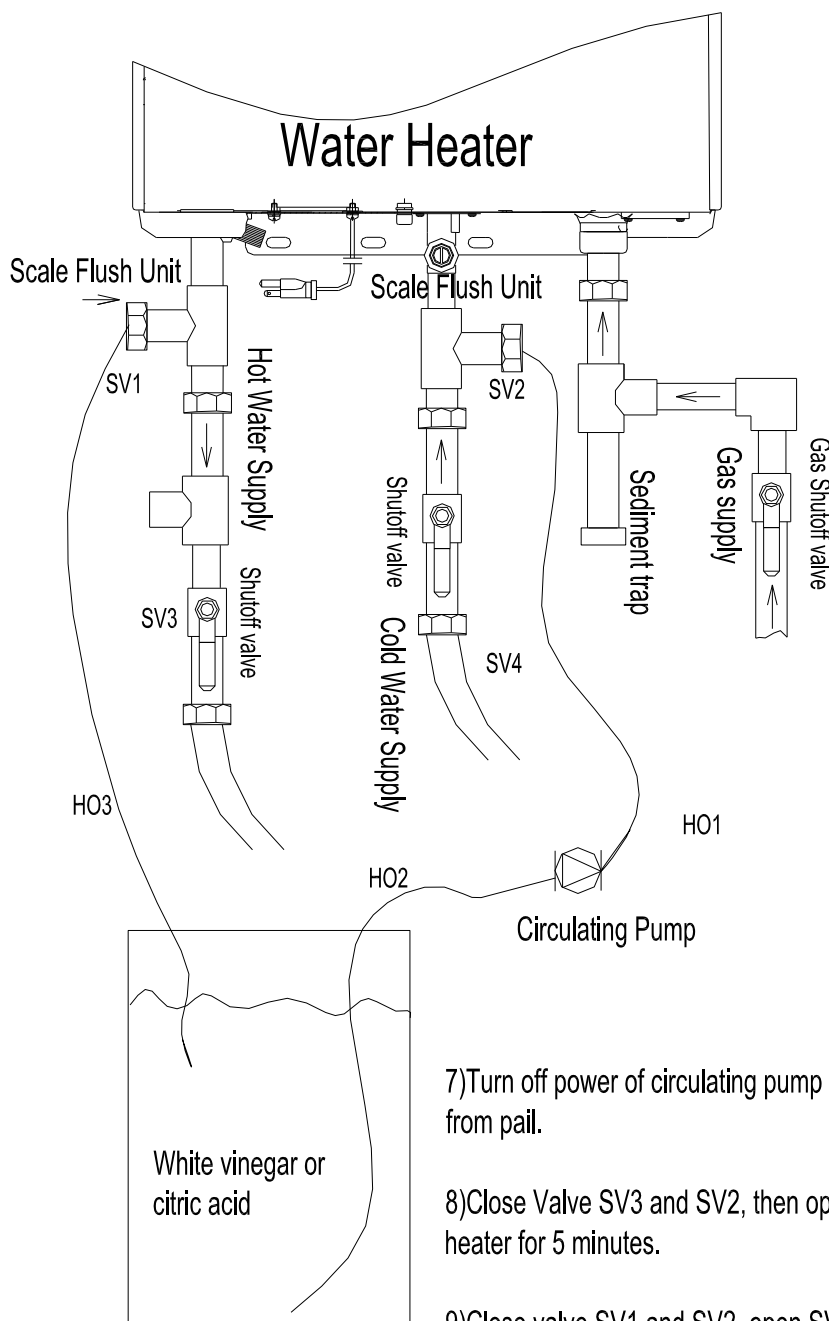

- 1) Turn off power to water heater.
- 2) Connect pump outlet with Hose HO1, connect pump inlet with Hose HO2.
- 3) Place free end of hose HO2 and HO3 into pail.
- 4) Connect SV1 with Hose HO3 and connect SV2 with Hose HO1.
- 5) Shut off Valve SV4 and SV3, open Valve SV1 and SV2
- 6) Turn on power of circulating pump to flush water heater 45 minutes.
- 7) Turn off power of circulating pump and remove Hose HO3 from pail.
- 8) Close Valve SV3 and SV2, then open SV4, to rinse water heater for 5 minutes.
- 9) Close valve SV1 and SV2, open SV3 and SV4, restart the power of water heater.

NATIONAL SECONDARY DRINKING WATER REGULATIONS

This part establishes National Secondary Drinking Water Regulations pursuant to section 1412 of

The Safe Drinking Water Act, as amended (42 U.S.C. 300g–1). These regulations control contaminants in drinking water that primarily affect the aesthetic qualities relating to the public acceptance of drinking water. At considerably higher concentrations of these contaminants, health implications may also exist as well as aesthetic degradation. The regulations are not Federally enforceable but are intended as guidelines for the States.

These are the secondary maximum contaminant levels for public water systems:

Contaminant	Level
Aluminum	0.05 to 0.2 mg/l.
Chloride	250 mg/l.
Color	15 color units.
Copper	1.0 mg/l.
Corrosivity	Non-corrosive.
Fluoride	2.0 mg/l.
Foaming agents	0.5 mg/l.
Iron	0.3 mg/l.
Manganese	0.05 mg/l.
Odor	3 threshold odor number.
pH	6.5–8.5.
Silver	0.1 mg/l.
Sulfate	250 mg/l.
Total dissolved solids (TDS)	500 mg/l.
Zinc	5 mg/l.

These levels represent reasonable goals for drinking water quality. The States may establish higher or lower levels which may be appropriate dependent upon local conditions such as unavailability of alternate source waters or other compelling factors, provided that public health and welfare are not adversely affected. If levels are higher than in this chart provided you may want to talk with local Water Department, Well Driller Companies, Building Department, or Local Government to determine if water treatment / conditioning may be an option to reduce scaling in this water heater.

Greenworks Unlimited suggests installing a water softener if water is more than 11 GRAINS per gallon.

NOTE: Keeping this water heater controller set at 110° F to 115° F will significantly reduce scaling to the water lines in less than favorable conditions.

TROUBLE SHOOTING

Introduction:

The ECOHOT™ burner is activated by a water flow valve. Numerous water related problems can cause this water valve to malfunction such as:

1. Insufficient water flow volume to activate the burners at its minimum flow requirement.
2. Dirt in the water flow valve causing it to malfunction.
3. Sediment build-up in faucet, or shower head.
4. Uneven pressure between cold and hot (with single valve faucets).
5. Plumbing crossovers.

These water flow related problems can cause the heater to deliver less than its full output, or to fail to ignite or to shut down completely. (Always unplug power supply before removing cover.)

No spark at the pilot:

Cross over in water lines. To confirm there is no cross-over in the plumbing, shut off the cold water supply to the ECOHOT™ and open a hot water faucet. There should not be any water flowing at any faucet. Water running is a sign of a plumbing cross-over. Consult your plumber.

Water flow is not sufficient to activate heater.

1. Water flow rate at faucet is below minimum flow needed to activate this appliance do to clogged screens/filters or restricted water pipes. Consult your plumber.
2. Water inlet screen is clogged. Water flow is restricted, preventing needed flow to activate heater. Clean water inlet screen (See Fig. 1).
3. Water valve parts may be dirty or components damage, water valve and component parts must be completely free of dirt. In hard water areas water valve parts may be corroded to a point where they will need replacing. Check for any sign of moisture or corrosion is at the joints of the water valves and/or components. Replace or service if needed immediately.
4. Poor circuit connections at the Over Heat Sensor (ECO) or the flue gas safety device. Ignition sparker will not operate if the electrical circuit is interrupted. Check that the connections to the ECOHOT™ and "Flue Gas Safety Device" are secure.

SPARK APPEARS AT PILOT WHEN HOT WATER TAP TURNED ON, BUT PILOT AND BURNERS WILL NOT IGNITE.

Note: Air in the gas line is normally a problem at time of initial installation, after the pipes have been worked on, or after a gas supply line has been allowed to empty. Bleed the air trapped in the gas line by turning the hot water faucet on and off until the air has been cleared from the line.

No gas to the ECOHOT™

1. Gas cock on gas line may not be open.
2. Gas regulator may be shut or damage. Replace or unlock the regulator. Excessive pressure will lock it up. Locking usually happens when using propane gas if the gas pressure between the gas tank and the water heater's gas regulator has not been reduced. To unlock

a regulator, consult your gas supplier or call **ECOHOT™** at 1-877-5ECOHOT (1-877-532-6468)

3. Pilot orifice or gas valve is dirty. Clogging of the pilot burner can be caused by dust in the air or dirt in the gas. The pilot orifice or gas filter may need to be cleaned or replaced.

Flow:

The flow rate through the **ECOHOT™** is limited to a maximum of 8.4 GPM at 45 °F rise. The temperature of the water will determine the flow rate output of the appliance based on your local ground water temperature and your desired outlet water temperature combination.

Based on the Applianceed States Department of Energy method of testing water heater output, the **ECOHOT™** is rated for 348 Gallons per hour (GPH) or 5.8 Gallons per minute (GPM), when raising the water temperature by 65 °F (for example from 54 °F to 115 °F). Refer to the following chart of typical household plumbing fixture flow rates to determine what **ECOHOT™** can do in a household application.

(Actual water flow will be higher when mixed with cold water)

Household Flow Rates:		<i>Taken from UPC 1997</i>	
<i>Appliance/ Use</i>	<i>Flow Rate (GPM)</i>	<i>Appliance/ Use</i>	<i>Flow Rate(GPM)</i>
Lavatory Faucet	1.0	Kitchen Sink	1.5
Bath Tub	4.0	Dishwasher	1.5
Shower	2.0	Washing Machine	2.0

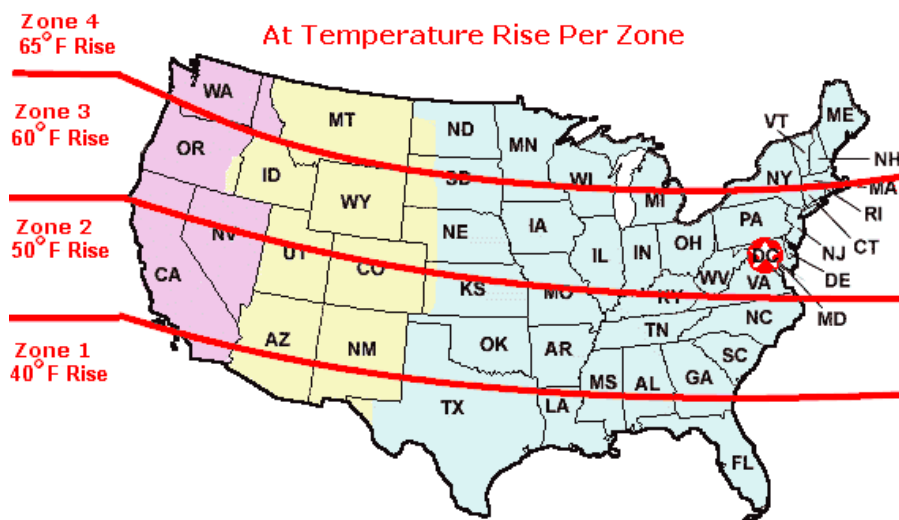

TEMPERATURE SETTING

There is a remote temperature gage with digital display from 95 °F (35 °C) to 140 °F (60 °C). Greenworks Unlimited™ recommends temperatures stay at or below 120 °F to prevent lime build-up inside the “heat exchangers” copper lines.

 **WARNING**

To help prevent scalding the outlet hot water temperature of the ECOHOT™ we recommend setting the temperature at a maximum of 120 °F (49 °C)

FREEZE PROTECTION DEVICES

This appliance comes equipped with heating blocks to prevent freezing which can damage the heat exchanger. For this freeze prevention system to operate there has to be electrical power to the appliance. Damage to the heat exchanger caused by freezing temperature due to power loss is not covered under the warranty. This water heater has been rated for temperatures down to 5 °F (-15 °C) in wind free environment. If you install the water heater in an area that is subject to temperatures (including wind chill) below 5 °F (-15 °C), this will void warranty and ECOHOT will not be responsible for any damage to the heat exchanger as a result of freezing.

If you will not be using your heater for a long period of time or if the temperature (including the wind chill) drops below 5 °F (-15 °C) turn off your heater and drain the appliance of water.

Error Code

Error Code	Description	Reasons/Repair
E0	Inlet water temperature sensor.	© Possible short in sensor/may need replacement of sensor/check wire to water temperature sensor it may be disconnected.
E1	Ignition fail or lost flame	©Hardware error in detecting the flame feedback/check gas supply/call ECOHOT. ©No flame detection after ignition 6 seconds/check gas supply/call ECOHOT ©Lost flame when burning/check gas supply/call ECOHOT
E2	Communication Error	©Hardware error in PCB controller/call ECOHOT.
E3	Fan voltage error	©Fan driver error, cannot detect voltage or current/check power supply. ©Vent pipe is blocked or wind pressure is too high/check flue pipe-exhaust for blockage/call ECOHOT.
E4	Fan error	©Fan not working/check power supply. ©Low fan speeds/check for blockage of exhaust/call ECOHOT
E5	Overheat	©Water temperature more than (185 °F/ 85 °C)/outlet water temperature sensor not working/thermostat is not working properly/loose wire to sensor/call ECOHOT
E6	Outlet water temperature error	© Possible short in sensor/may need replacement of sensor/check wire to water temperature sensor it may be disconnected.
E7	Selection switch error	©Controller board error/ Call ECOHOT
E8	Heat Exchanger temp sensor error	© Possible short in sensor/may need replacement of sensor/check wire to water temperature sensor it may be disconnected.
F1	Hi Limit thermostat open	©Controller board error/ Call ECOHOT
F2	Gas Valve driver circuit	©Controller board error/ Call ECOHOT

	error	
F3	The power of Gas Valve error	©Controller board error/ Call ECOHOT
F4	Main Valve control circuit error	©Controller board error/ Call ECOHOT
F5	Proportional Valve driver circuit error	©Controller board error/ Call ECOHOT
F6	AD converter error	©Controller board error/ Call ECOHOT
F7	Setting Switch error	©Controller board error/ Call ECOHOT

- ©The error status will keep locked until the “On/Off” is pressed or if you reopen the water flow.
- ©Error “E7” will keep this appliance locked to unlock turn off and then back on or unplugged this appliance and plug in again.
- ©The Beeper will beep 3 times per second whenever error happens.

Call ECOHOT Tech Support 1-877-5ECOHOT (1-877-532-6468)

PARTS LIST

No	Part Code	Part Name	Quantity	Remark
203	JSW32AU05_04	Flue gas collector	1	
204	010466	Heat exchanger assembly	1	
205	T1/11	Hi-limit thermostat (80 °C)	1	
206	JSG32AU05_DL11	Hi-limit and fuse connector	1	
207	JSG32AU05_DL07	Flame feedback cord	1	
208	DHS-M4	Ignition assembly	1	
209	JSQ32A_07	Combustion chamber cover	1	
210	JSG32AU05_03Bx	Gas tube appliance	1	x=1:NG , x=2:LPG
211	JSG32AU05_DL14	Ignition Assembly cord	1	
212	JSQ24A_07	Gas valve assembly	1	
213	JSG32AU05_DL05	Transformer assembly	1	
214	FY6215I_00	Wind Pressure Switch	1	
215	JSG32AU05_09	Water control assembly	1	
216	JSG32AU05_DL15	Wind pressure switch cords	1	
217	JSG32AU05_DL04	Gas Valves cords	1	
218	JSR10.07	Inlet gas connector	1	
219	JSG32AU05_12	Inlet water connector	1	
220	JSG32AU05_DL10	Valve cord assembly	1	
221	JSG32AU05_DL08	Remote controller connector	1	
222	JSG32AU05_13	Outlet water connector	1	
223	Y01KO3000SE2_DL01	Power cable assembly	1	
224	JSG32AU05_DL13	Outlet water temperature sensor	1	
225	JSG32AU05_10	Fan assembly	1	
227	JSG32AU05_04	Combustion chamber	1	
228	JSQ32A_05	Burner assembly	1	
229	GB845-85	Cross self-taping screws	2	ST2.9*8
230	JSQ32A-4	Fuse support	4	3Cr13φ0.4
231	JSQ24A-11	Protection tube	4	
232	GB9074.3	Cross screws	26	M4*8
233	JSQ16A-3	Sealing tape	2	PP φ2
234	JSQ24A-8	Proportional valve O-ring 1	1	φ 24.8×φ.5
235	JSQ24A-9	Proportional valve O-ring 2	1	φ 20.8×φ3.5
236	SJ2829-87	Cross screws	1	M4*6
237	JSPQ10C.06-1	Washer	1	δ 1
238	JSG32AU05-2	Proportional valve testing tube	1	HPb59-1
239	JSQ32A-1	Transformer board	1	
240	SJ2829-87	Cross screws	4	M4*10
241	WHG8BHK_00-4	Plastic washer	4	

242	JSG32AU05-1	Wind pressure support	1	
243	JLG1.20-1	Pipe connector cap	3	
244	JLG1.11.01-05Z	Plastic Washer	3	3/4"
245	WHX60-12-05	Cord clip	1	
246	JSQ8P1-1	Y-type screw	1	
247	GB6170-86	Screws M4	2	
248	GB862.1-87	Washer 4	1	
249	JSW16A_00-01	Sealing cap	1	
250	WHQ8E.00-02	Temperature sensor O-ring	1	
251	JSQ32A-3	Inlet water connector washer	2	
252	JSQ24A-5	Connector clip 1	1	
253	JSG32AU05-6	Wind pressure tube	1	
254	WHQ8.00-02	Wind pressure tube protection springs	2	
255	WHQ7B.07.01-00	Wind pressure connector	1	
256	GB9074.3	Cross screws	12	M4X12
257	SJ2823-87	Cross self-taping screws	24	ST4X10
258		Self-taping screws	13	M4×6
259		Adjust screw of proportional valve	1	
270	JSW32AU05_01Bx	Water heater front cover assembly	1	x=1:NG , x=2:LPG
271	JSW32AU05_02Bx	Water heater bottom cover assembly	1	x=1:NG , x=2:LPG
272	JSW32AU05_DL01	Main controller assembly	1	
273	JSW32A-1	Flue pipe sealing washer	1	
274	JSW32A_03	Flue exhaust connector assembly	1	
275	JSW24A-1	Flue exhaust connector support	2	

For maintenance parts, Call ECOHOT 1-877-5ECOHOT (1-877-532-6468)

Figure 1 Interior Diagram

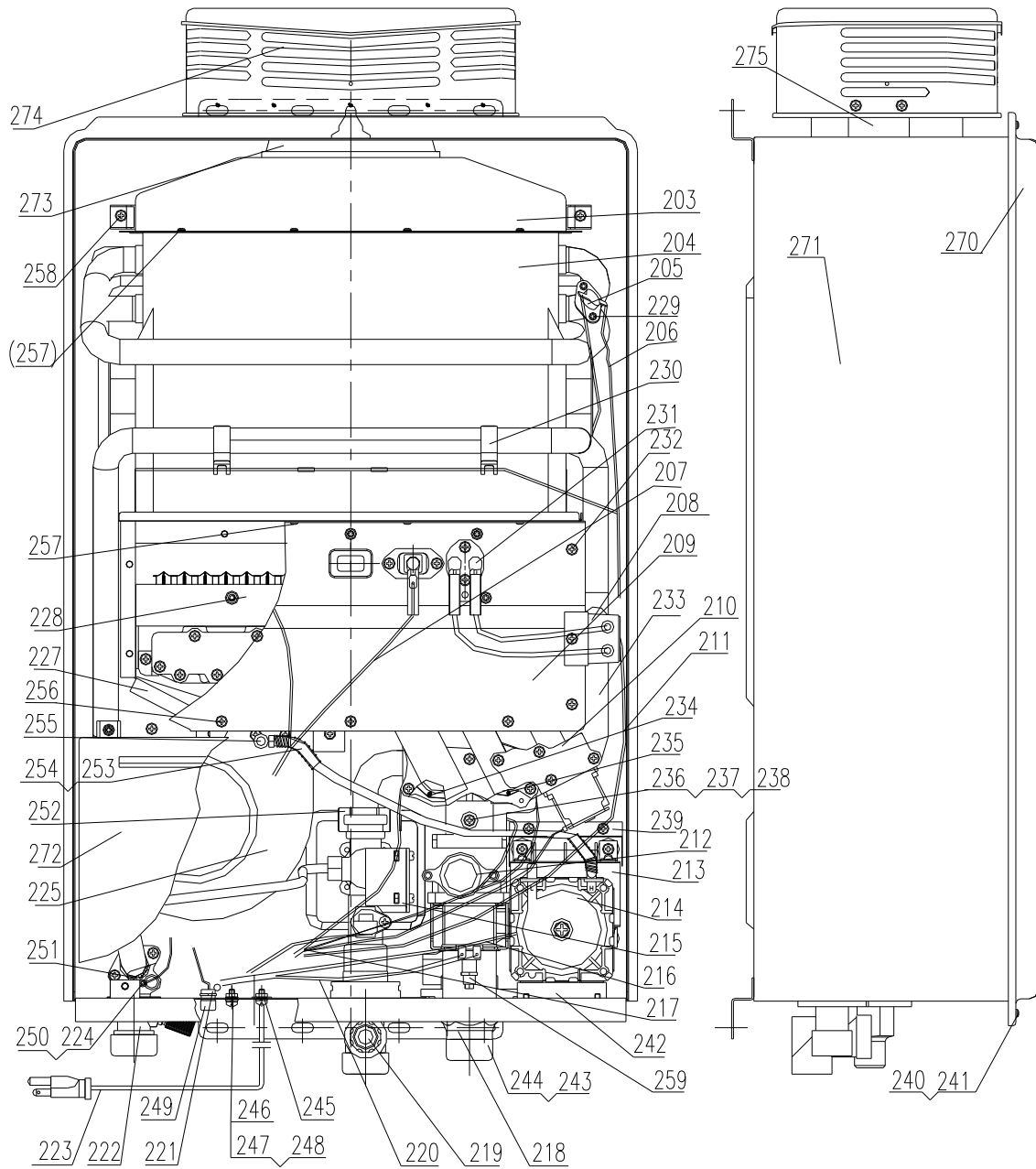

Figure 2: Plumbing Installation

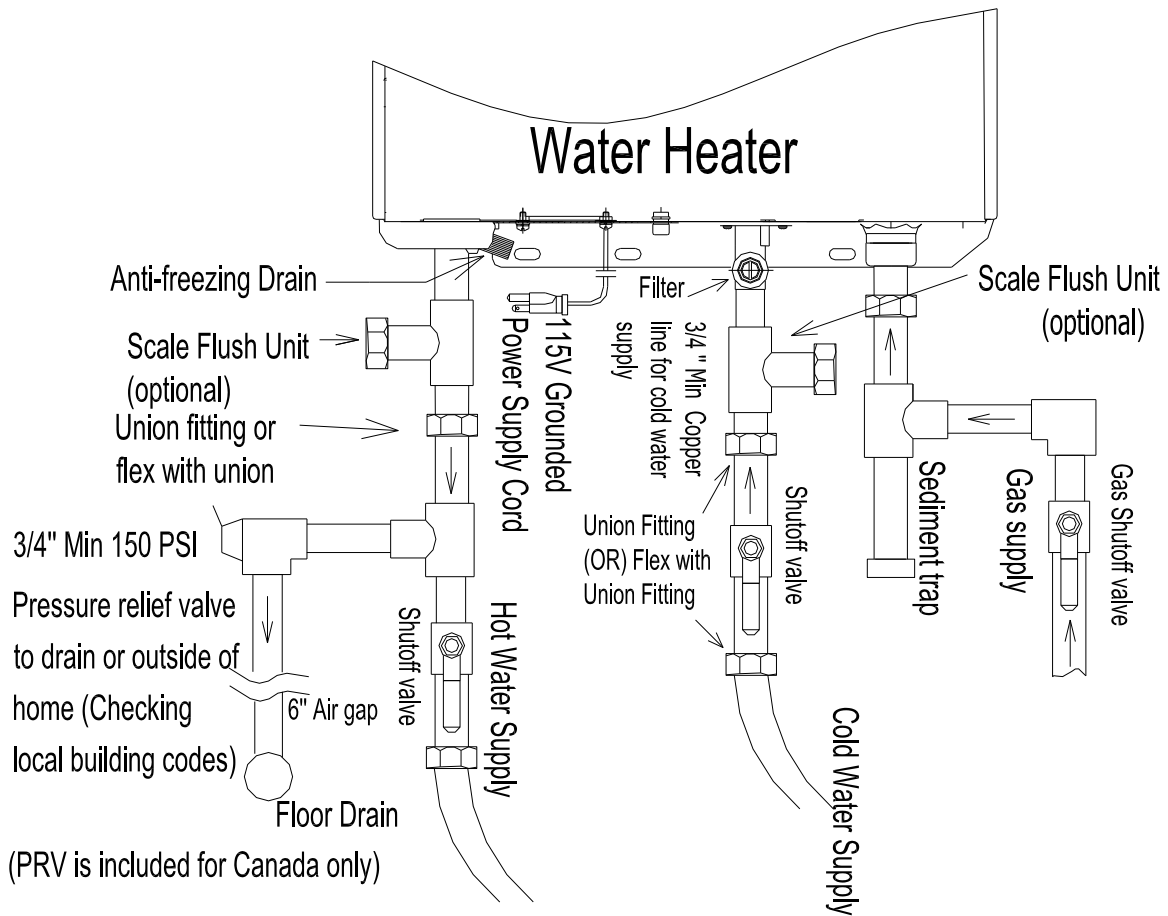

Figure 3: Front & Side Views

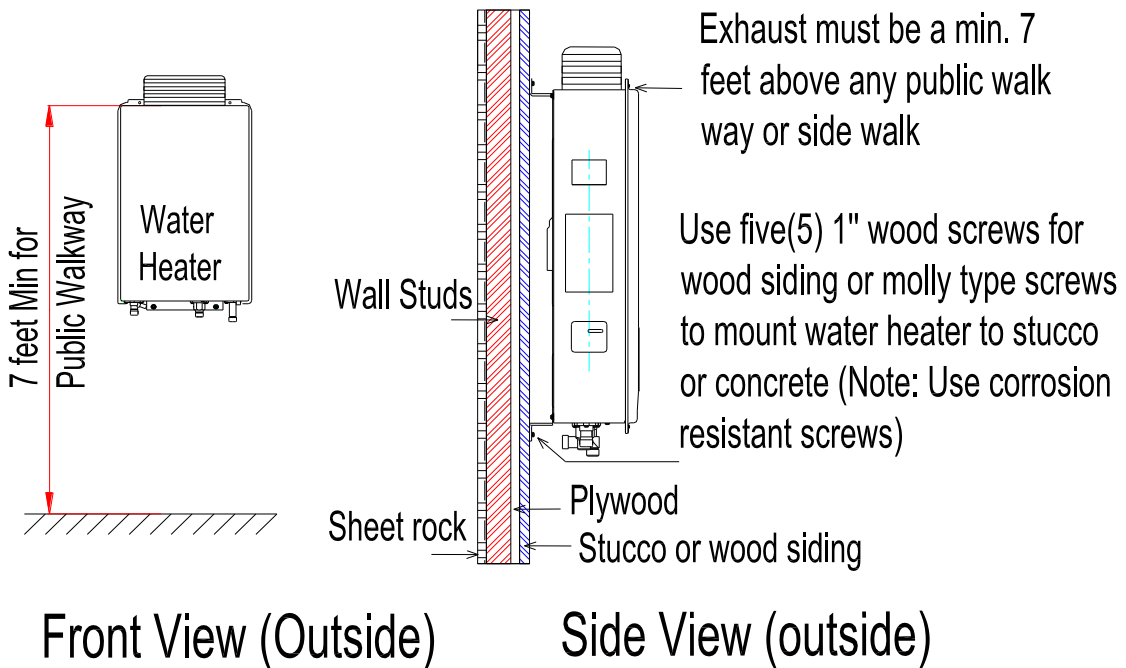
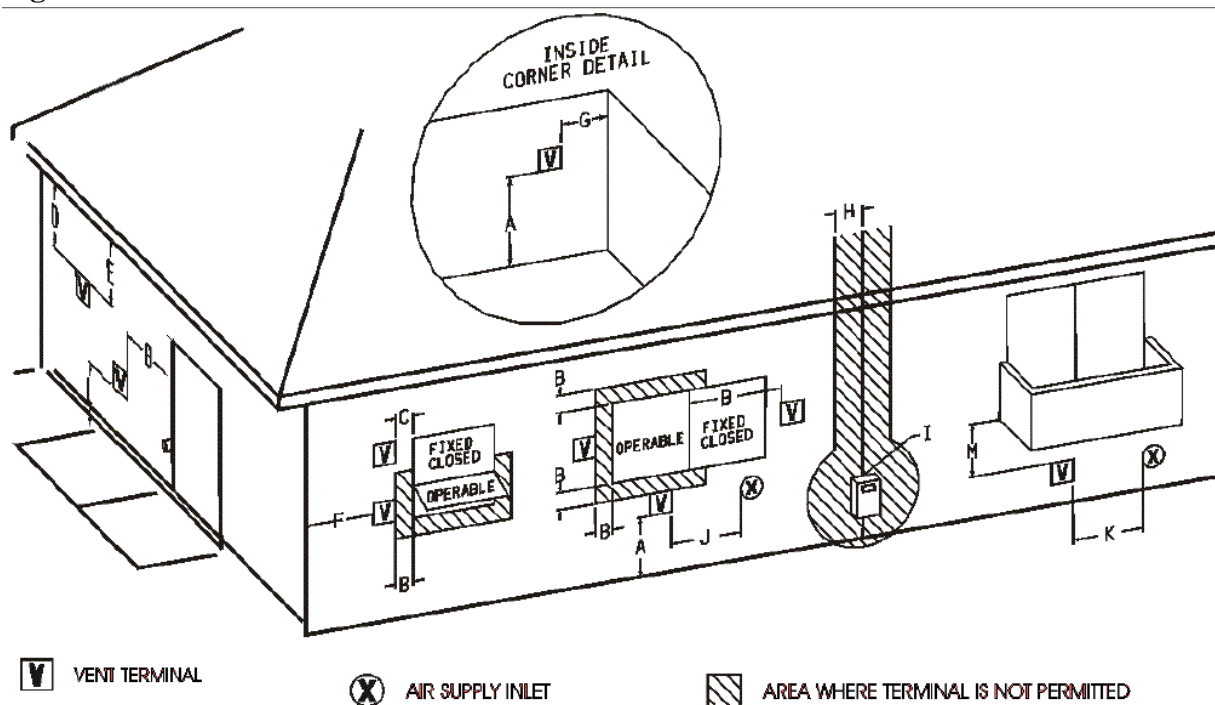

Figure 4: Direct Vent Terminal



	Canadian Installation(1)	US Installation(2)
A= Clearance above grade, Veranda, porch, deck, or balcony	12 inches(30cm)	12 inches (30cm)
B= Clearance to window or door that may be opened	6 inches (15cm) for appliances <10,000Btuh(3kW), 12 inches(30cm) for appliances > 10,000Btuh(3kW)and ≤100,000 Btuh(30kW), 36inches(91cm) for Appliances>100,000Btuh(30kW)	6 inches (15cm) for appliances <10,000Btuh(3kW), 9 inches(23cm) for appliances > 10,000Btuh(3kW)and ≤50,000 Btuh(15kW), 12inches(30cm) for Appliances>50,000Btuh(15kW)
C= Clearance to window or door That may be opened	*36"	*48"
D= Clearance to permanently Closed window	*12"	*12"
E= Clearance to unventilated Soffit Or Eves	*3 Feet Min.	*3 Feet Min.
F= Clearance to outside corner	*12"	*12"
G= Clearance to inside corner	*24"	*24"
H= Clearance to each side of Center line extended above Meter/regulator assembly	3 feet(91cm) within a height 15 feet above the meter/regulator assembly	*36"
I= Clearance to service regulator Vent outlet	6 feet(1.83m)	*6 feet (1.83m)

J= Clearance to non mechanical Air supply inlet to building or the combustion air inlet to any other appliance	6 inches (15cm) for appliances <10,000Btuh(3kW), 12 inches(30cm) for appliances> 10,000Btuh(3kW)and ≤100,000 Btuh(30kW), 36inches(91cm) for Appliances>100,000Btuh(30kW)	6 inches (15cm) for appliances <10,000Btuh(3kW), 9 inches(23cm) for appliances> 10,000Btuh(3kW)and ≤50,000 Btuh(15kW), 12inches(30cm) for Appliances>50,000Btuh(15kW)
K= Clearance to a mechanical air Supply inlet	6 feet(1.83m)	3 feet(91cm) above if within 10 feet(3m) horizontally
L= Clearance above paved Sidewalk or paved driveway located on public property	7 feet(2.13m) †	*
M= Clearance under veranda, Porch deck, or balcony	12 inches(30cm) ‡	*

(1)In accordance with the current CSA B149.1 *Natural Gas and Propane Installation Code*

(2)In accordance with the current ANSI Z223.1/NFPA 54 *National Fuel Gas Code*

†A vent shall not terminate directly above a sidewalk or paved driveway that is located between two single family dwellings and serves both dwellings.

‡Permitted only if veranda, porch, deck, or balcony is fully open on a minimum of two sides beneath the floor.

⊗For clearances not specified in ANSI Z223.1/NFPA 54 or CSA-B149.1, one of the following shall be indicated:

- a) A minimum clearance value determined by testing in accordance with section 2.20, or ;
- b) A reference to the following footnote

Note: ECOHOT Minimum Clearances:

Sides 12"

Floor 12" (or 12" above snow levels)

Eaves or Gutters 36"

Front 24"

Back 0"

BE SURE TO KEEP VEGITATION GROWTH CLEAR FROM WATER HEATER.

Figure 5: Wiring Diagram

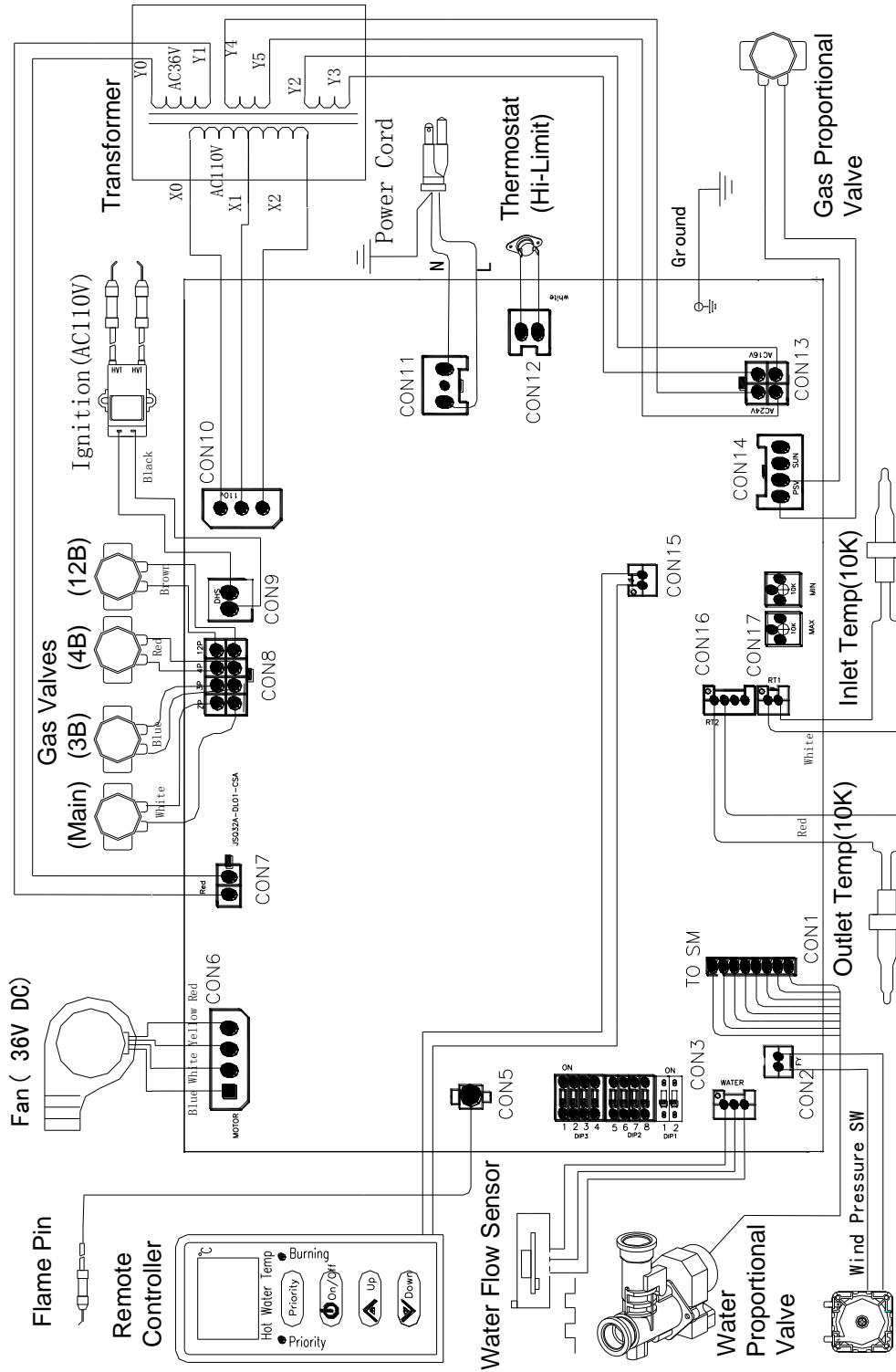

Caution: Label all wires prior to disconnection when servicing controls, Wiring errors can cause improper and dangerous operation.
 Verify proper operation after servicing.

Figure 6: Tankless Water Heater with Domestic Recirculation Loop

Below is a Diagram installation to avoid occasional spikes in temperatures and cold pockets of water inherited with Tank-less unit usage, along with instant hot water convenience and a savings of 20% + in household water use (average home). Greenworks suggest installing this type of system.

Greenworks Tankless Water Heater
 With Domestic Recirculation Loop

